



DCM2000, DCM2500, DCM2570

Pristine sound, brute power and no-fault reliability make the DCM amps the power amp of choice for pro audio. Massive Toroid power supplies with huge capacitors deliver the bass that kick drums demand. Designed for continuous operation, overheating is not a problem especially down at minimum impedances where other amps simply turn off.

Each DCM is hand built at our San Diego factory featuring all steel construction, recessed controls and heavy-duty power components. The rock-solid, efficient design with its superb testimonial-proven sound makes the USA built DCM an amp you'll own for years.

**PURE—TRANSPARENT SOUND**

Carvin considers the sound of an amp equally important as to its reliability. To insure pure, uncolored sound, we build one of the fastest power stages on the market today. High slew rates of 50v/μs deliver superb transient response. High frequencies are transparent and open—even at extreme levels. Linear feedback circuits reduce distortion to near the theoretical zero limit preventing harshness which would lead to ear fatigue. The DCM deliver transparent, unaltered sound—especially important to the studio user. Drive any type of reactive loads, including 70V transformer distribution systems.

**ULTRA RUGGED FOR TOURING**

Every chassis is made from heavy-duty 16 gauge steel that is plated before painted to prevent rust. All internal cabling is neatly tied and harnessed. Every circuit card is FR-4 MILITARY SPEC, double-sided, fire retardant glass epoxy. Plated through-holes insure that the solder flows on the top, bottom and through each hole of every component preventing components from shaking loose. Speakon™ connectors, heavy-duty power switches, recessed knobs, all give the DCM amps a “tank-like” ruggedness.

**TOROID POWER SUPPLY**

Toroids deliver massive amounts of “on demand” current for continuous 2 ohm operation. This gives the power supply a solid foundation, yielding more headroom for large subwoofer applications. Not only do toroids deliver high current, but they are known for reducing stray magnetic fields eliminating hum & noise. This is especially important to the recording industry.

**MODULAR CONSTRUCTION**

With the DCM Series, Carvin brings you totally modular construction. If you ever need an I/O (input/output) connector card because a connector wore-out, just unplug and re-install the replacement card. This applies to every aspect of the DCM Series amps including the power supply, power cards, heat sinks and fans. Everything is connected by heavy-duty AMP™ and MOLEX™ type connectors for easy replacement—even the Toroid transformer is a plug-in.

**DISTORTION-FREE LIMITERS**

The purpose of a limiter is to hold down peaks so the amp won't distort with extra hot input signals (helps protect speakers). In addition, a well designed limiter can increase your amp's average output as much as 3 dB allowing levels to be turned up without peak distortion. Part of Carvin's design uses the more expensive, distortion-free linear “opto isolators”. Unlike amps that use FET controlled limiters, which inject small amounts of distortion, the DCM Series limiters keep your sound pure and uncolored!

**FRONT PANELS & CONNECTING UP**

**RECEIVING INSPECTION—read before getting started**

INSPECT YOUR UNIT FOR ANY DAMAGE which may have occurred during shipping. If any damage is found, please notify the shipping company and CARVIN immediately.

SAVE THE CARTON & ALL PACKING MATERIALS. In the event you have to re-ship your unit, always use the original carton and packing material. This will provide the best possible protection during shipment. CARVIN and the shipping company are not liable for any damage caused by improper packing.

SAVE YOUR INVOICE. It will be required for warranty service if needed in the future. SHIPMENT SHORTAGE. If you find items missing, they may have been shipped separately. Please allow several days for the rest of your order to arrive before inquiring.

RECORD THE SERIAL NUMBER on the enclosed warranty card or below on this manual for your records. Keep your portion of the card and return the portion with your name and comments to us.

USA customers register online at: [www.carvin.com/registration](http://www.carvin.com/registration)  
All other countries register online at: [www.carvinworld.com/registration](http://www.carvinworld.com/registration)

The DCM Series feature front panel signal, peak and protect LEDs which let you monitor the status of the amp. Both channels use detente level controls allowing you to see your settings at a glance. Balanced TRS & XLR input connectors are used to eliminate hum & noise. Speaker outputs feature heavy-duty binding posts, Speakon™ connectors and 1/4” jacks.

The rear professional accessory group offers a GROUND switch to remove the chassis ground from the XLR input. A PARALLEL input switch connects the inputs together eliminating Y cables for patching multiple amp systems. The accessory group also features a BRIDGE MODE switch to deliver twice the power into a “mono” load or full power into a 70V distribution system, and a LIMITER ON/OFF switch gives the choice of using the internal limiter circuitry.

**DCM POWER AMP SPECIFICATIONS:**

MODEL	DCM2000	DCM2500	DCM2570
<b>Bridged RMS Continuous</b>			
4Ω (20-20k Hz, <1.0%)	2000w	2500w	—
8Ω (20-20k Hz, <1.0%)	1400w	1700w	2400
<b>Both Channels RMS Continuous</b>			
2Ω (20-20k Hz, <1.0%)	1000/1000w	1250/1250w	—
4Ω (20-20k Hz, <1.0%)	700/700w	850/850w	1200/1200
8Ω (20-20k Hz, <1.0%)	425/425w	500/500w	700/700
THD (20-20k Hz 50% power)	0.03%	0.03%	0.03%
THD (20-20k Hz 90% power)	0.1%	0.1%	0.1%
Damping Factor:	>500	>500	>500
Slew Rate: bridged mode	>50v/μs	>50v/μs	>50v/μs
Sensitivity: (4Ω, Vms)	1.0 V	1.0 V	1.0 V
Signal to Noise Ratio:	Above 100dB		
Frequency Response:	±0.5 dB, 20 Hz to 20kHz (±1.5 dB, 10 Hz & 40 kHz)		
Input Impedance:	>20K Ω, balanced		
Protection Circuits:	Short Circuit • No Load Protection • SpeakerGuard™ • Thermal Shut-Off • Mute On/Off		
Control and Indicators:	Front: Power switch • Recessed detente attenuators • Signal LED • Clip LED • Protect LED • Power Indicator Rear: Ground Lift (each channel) • Parallel Input Switch • Speaker Output Bridge Switch • Limiters IN/OUT Switch • Input Connectors: Two each; Balanced XLR & 1/4” • Speaker Output Connectors: Dual heavy duty binding posts, three Speakon™ & four 1/4”		
Internal Fuse	SLOW BLOW - DCM2000, DCM2500, DCM2700: 25A, 240V/15A		
Dimensions:	5 1/4” High x 19” Wide x 10” Depth (3-space): 13.3 x 48.3 x 25.3 cm		
Net Weight:	DCM2000: 34 lbs. (16.4Kgs), DCM2500: 39 lbs. (16.6Kgs), DCM2570: 39 lbs. (16.7Kgs)		

For your records, you may wish to record the following information.  
Serial No. \_\_\_\_\_ Invoice Date \_\_\_\_\_



12340 World Trade Drive, San Diego, CA 92128  
800.854.2235 www.carvin.com



## FRONT PANEL

### 1. MOUNTING

Sturdy one piece 12 gauge steel face plate accommodates standard 19" rack installation. The rack mounting holes are designed on ISO standard spacing. Four 10-32 x .5" phillip machine screws are normally used to secure the amp. Rear support brackets are not required.

### 2. POWER SWITCH

Check the power amp connections and verify the AC line power source before engaging the POWER switch. The yellow LED unmistakably indicates that all circuits are properly powered up. Yellow is used so the operator can see the red indicators (clipping or protect) from a distance.

### 3. CHANNEL LEVEL CONTROL

A precision input LEVEL attenuator is used to adjust the volume levels. To deliver the amps maximum power without reducing the headroom of the signal source, the level controls should be turned full on.

### 4. CHANNEL SIGNAL INDICATOR

The green SIGNAL LED indicators will start to flash when there is a signal passing to your speakers (-30dBμ). This lets you know when the amp is passing a signal to your speaker connectors.

### 5. CHANNEL CLIP INDICATOR

The red CLIP LED indicators will start to flash when each channel has reached its maximum output. Occasional flashing caused by lower bass frequencies is OK. However, consistent flashing caused from higher frequencies may damage high frequency drivers (excessive distortion). This does not cause damage to the amp.

### 6. COOLING VENTS/FAN

Upon rack installation, the rear of the amp must be fully exposed to room temperature air. The surrounding air should not be warmer than 120°F or the thermal protection could activate the PROTECT LED. The front cooling vents are not to be restricted from exhausting the warm air.

### 7. PROTECT LED INDICATOR

The red PROTECT LED provides the operator with information about the status of the amplifier. The PROTECT LED can come on under 3 different conditions (when this happens both channels are muted by disconnecting the output speaker relays protecting your speakers):

- 1) During power-up, the amplifier stays in a muted state for approx. 3 sec until it determines that everything is functioning normally (no output shorts or over temp conditions).
- 2) When the output load draws excessive current or a direct short is detected caused by a shorted speaker cable or speaker system, the RED PROTECT LED will illuminate. Reset this condition by turning the amp off for two seconds and then on again. Check for shorted cables and the total speaker system impedance connected to each channel.
- 3) Overheating is usually determined when the amp stops in the middle of a performance and the PROTECT LED comes on. If this is the cause, leave the amp on for the fan to cool the amp down. The amp will automatically reset within 1 to 3 minutes. The PROTECT LED will turn off when ready. Check for the following conditions: a) The rear intake air is restricted, b) The intake air is extremely warm, c) The front exhaust vents are restricted, or d) Excessive speaker load (try other speakers or remove speakers if you have more than one connected to each channel). The minimum impedance is 2 ohms per ch or 4 ohms BRIDGED. DCM2570 minimum load is 4 ohms per ch or 8 ohms BRIDGED.

## REAR PANEL

### 8. CHANNEL INPUTS AND THROUGH

Balanced or Unbalanced 1/4" TRS inputs can be used along with the balanced XLR's. The male "THROUGH" XLR connector carries the same signal as the female XLR to daisy chain channels or additional amps. XLR pin configuration: Pin 1: Grounded through the GROUND LIFT switch, Pin 2: positive Bal. signal and Pin 3: negative Bal. signal.

### 9. PARALLEL OR "Y" INPUTS

The rear PARALLEL switch "IN" allows you to drive both channels from either input in which a signal entering any input will be available on both channels eliminating Y adapters.

### 10. INPUT GROUND LIFT

Many times sound systems are connected in such a manner to cause a grounded loop with the inputs which result in audible hum. The input GND LIFT (1/4" & XLR) switch on the rear panel will help eliminate this problem. If not, another way to eliminate ground loops is to install Carvin's MTF55 "Ground Lifter" between the amplifier input and the signal source. This isolates the input ground from the AC power ground.

### 11. LO CUT (DCM2500, DCM2570)

The LO CUT switch inserts a 40Hz, 3rd order, high pass filter. This will remove sub audio frequencies from damaging speakers and wasting inaudible power. It is active when the switch is pushed "IN".

### 12. LIMITERS

To activate the LIMITERS, engage the rear limiter switch to the "IN" position. The built-in "optio" limiters are recommended to hold down peaks that could cause early distortion. This will help to raise the average power so that you can get more output from each channel. To check the effectiveness of the limiters when the channel starts to distort (under full output), engage the limiters and hear the reduction of the distortion. If the distortion stops, you can try to turn the channel up for more power. The lower bass frequencies are most affected. WARNING: Do not check in an environment where the sound level could damage your ears!

### 13. SPEAKER 1/4" AND SPEAKON™ OUTPUTS

The standard 1/4" SPEAKER jacks are offered for low power applications. Speakon™ connectors are provided for high power application. Secure the Speakon™ connection by turning to the right. The center Speakon™ is for Bridge only. Turn the amp off before connecting your speakers. DCM 2570 minimum load 4 ohms

### 14. BINDING POST OUTPUTS

For other high power speaker connections, use the rear BINDING POSTS to connect your speakers. Wire sizes up to 7 gauge (50 amps) can be inserted into the binding post "side holes". Larger cable can be used with "banana" plugs which plug into the end of the binding posts (remove colored caps from the top of the binding post). Binding posts are spaced on ISO standards. Use the two center RED binding posts to BRIDGE both power amps (see 15 BRIDGE MODE).

### 15. BRIDGE MODE—25V/70V DISTRIBUTION SYSTEMS

The "DCM" Series can be operated in bridge mode if you require a 25V / 70V distribution speaker system or a high powered mono (single channel) amp, which can double your power into a single load. With your amp off, push "IN" the rear (recessed) BRIDGE switch after you have made your connections to either the center bridge Speakon™ or the rear center RED binding posts (ch 1 is + and ch 2 is -). Select carefully or damage may result to your speakers. This is why the switch has been recessed. No other speaker connectors or binding posts can be used at the same time! The INPUT and LEVEL is handled by channel 1. Channel 2 is non-operational. The minimum speaker impedance is 4 ohms. CAUTION: The power developed by bridging your amp can destroy most speaker systems! DCM2570 minimum load is 8 ohms in BRIDGE

### 16. AC POWER

Your amp is designed to run on either 120V 60 Hz or 240V 50Hz depending on the model purchased. The voltage range for 120V model is 95V to 132V and for 230V model it is 195V to 255V. The rear heavy-duty AC receptacle will accept a standard grounded AC cord that is designed for your country. Be sure to check your power source before plugging into a grounded (3 prong) outlet. Never defeat the grounded connection or electrocution may result! Firmly push the power cord all the way into its receptacle. In the case of a blown fuse; unplug the amp, remove the lid and replace the fuse located in the back corner above where the AC cord connects to the circuit board.

**FUSE:** The fuse is located within the main chassis above the AC connector mounted on the rear, inside the PC card. Normally if the fuse fails, the amp will require service. See spec. chart for fuse values.

**NOTE:** Each amp will require a dedicated circuit if you are driving the amp to its full output. There will be a sustained loss of power if the AC voltage falls below the rated 120V or 230/240V. Use a heavy gauge power cable and power source.

## TYPICAL STEREO SETUP

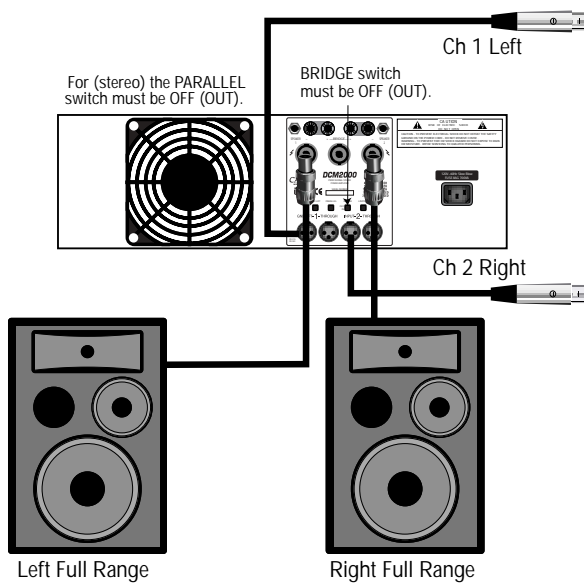

## BRIDGED MONO

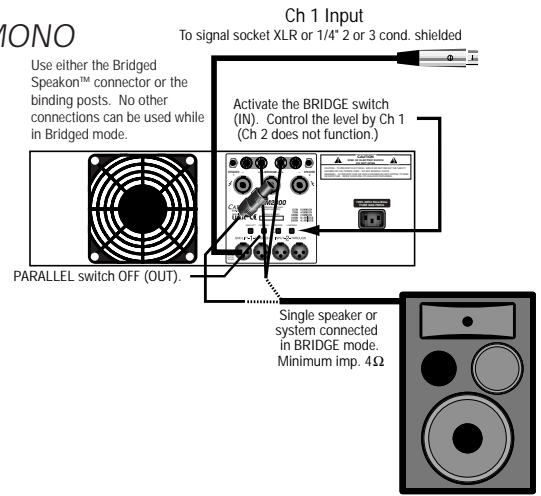

## 25V OR 70V DISTRIBUTION SYSTEM

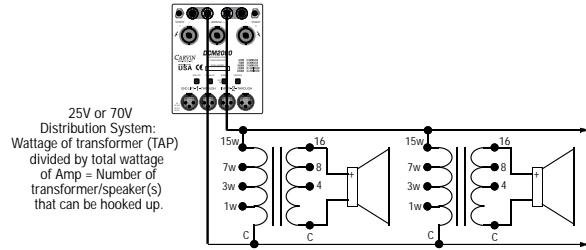

## MONO MAINS & MONITORS

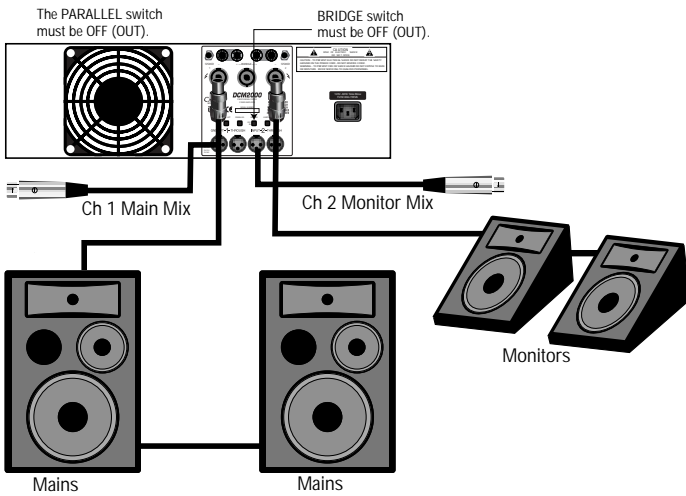

## STEREO BIAMPING

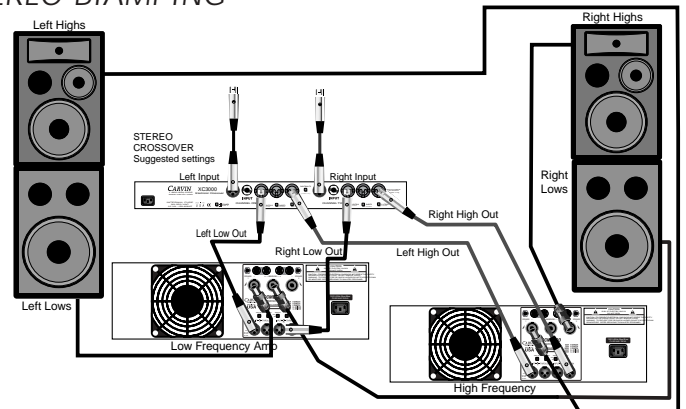

TS 1/4" Unbalanced  
Tip-Sleeve

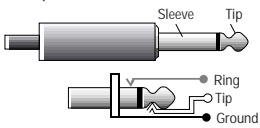

TRS 1/4" Balanced  
Tip-Ring-Sleeve

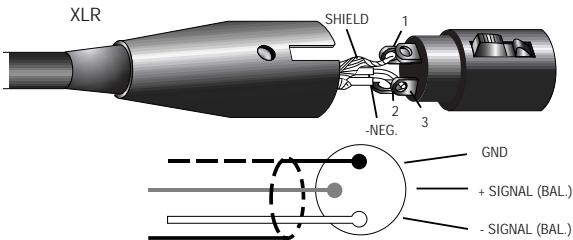
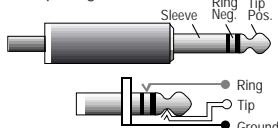

— Solder tinned wires 1/4"  
— Strip cable insulation back 3/4"

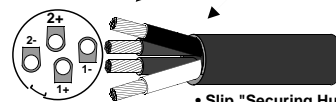

## Speakon™

- Slip "Securing Hub" then "Cable Clamp" over cable before attaching wires.
- Connection Configuration:  
Black (1+) / positive  
White (1-) / negative  
Red (2+) / positive  
Green (2-) / negative
- Solder wires in contacts or use hex screws provided.

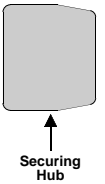
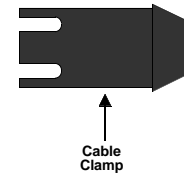
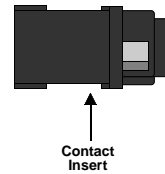
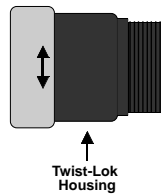

## HELPFUL HINTS

- 1) NO SOUND FROM CH 2: The rear (recessed) BRIDGE switch has been inadvertently pushed in.
- 2) STEREO CHANNELS SOUND THE SAME: The rear PARALLEL switch has been inadvertently pushed in.
- 3) NO HIGH FREQUENCIES: Tweeters or midrange drivers have been damaged or blown from feedback or to much power.
- 4) SYSTEM HUM: Switch the rear GND LIFT switch IN or OUT. If the hum is not eliminated, then install Carvin's MTF55 "Ground Lifter" between the amplifier input and signal source. This isolates the input ground from the AC power ground.
- 5) POOR SOUND (BASS): The speaker systems are wired out of phase to each other. To correct, reverse the wires on one speaker connector only and your sound, especially the bass response will improve.
- 6) DEDICATED CIRCUIT BREAKER: Each amp will require a dedicated circuit breaker for its full output. There will be a sustained loss of power if the AC voltage falls below the rated 120V or 230/240V input.

